

General Description

Dual P.O. Check D03 Cartpak Body.
 For additional information see Technical Tips on pages CB1-CB3.

Body Schematic

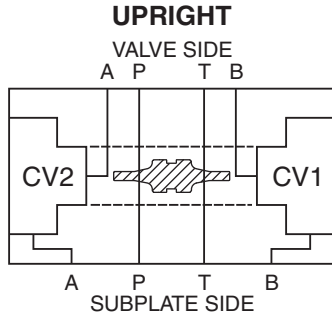

Ordering Information



Code	Plug Seals	Code	Body Material
Omit	Nitrile	A	Aluminum

Body supplied with:

- O-Rings and Drive Pin Kit

Functional assembly requires:

- CVH103P* - Check Valve - Qty. 2 - Ordered Separately
- 717917† - Pilot Piston - Qty. 1 - Ordered Separately

* Indicates spring pressure option
 † Indicates seal option

Requires Dual Pilot Piston

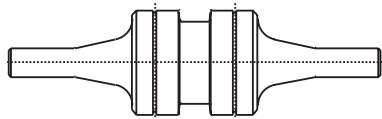

717917 Without Seal

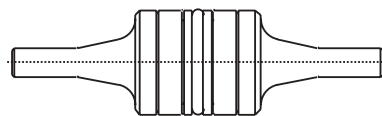

717917N With Buna N Seal

NOTE: 20 PSI check valve or higher recommended with sealed pilot piston.

Dimensions Millimeters (Inches)

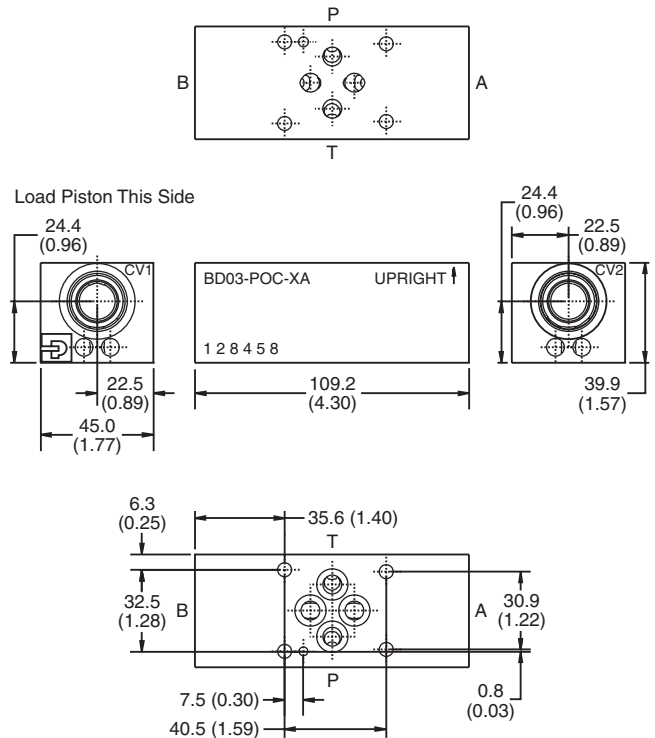

Dual Checks

Cavity CV1 and CV2:
 CVH103P

Check on CV1

CVH103P
 Load Piston This Side

Check on CV2

CVH103P

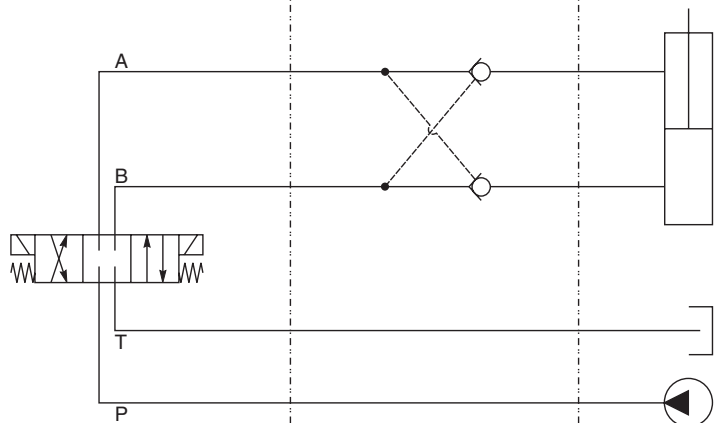

Dual Pilot Operated Check Valve